

# Asprova Link For SAP R/3 (Features)

Enable use of various features of Asprova on top of SAP

## Utilizing R/3 PP s extended module

1. Seamless data exchange made possible by using R/3 PP s extended module.
2. Various linking patterns are supported.

## Various Asprova features usable

1. High speed scheduling
2. Multi-item, multi-process support
3. Quick due date confirmation
4. Various scheduling features available
  - 1) Sub resources (workers, jigs, etc.)
  - 2) Setup times
  - 3) Move time between processes
  - 4) Alternative resources
  - 5) Version change
5. Forward, Backward, bottleneck centered scheduling
6. Easy manual tuning using user friendly GUI
7. Automatic order replenishment

# Asprova Link For SAP R/3 (Data I/O)

## Bi-directional interface between SAP R/3 and Asprova

### Download [R/3 to Asprova]

1. Download data from R/3 using BAPI (R/3 Transaction)  
Planned Order, Manufacturing Instruction, Current Stock,  
Purchase, Instruction Result
2. Filter data by plant and MRP user
3. Support code change from Planned Order to Manufacturing Order
4. Support matching between external code (Asprova issued) and internal code (R/3)
5. Support usage of order versions

### Upload [Asprova to R/3]

1. Upload data to R/3 using BAPI  
Planned Order Header (Add/Update/Delete) -> Asprova Order  
Manufacturing Instruction Header (Add/Update/Delete) -> Asprova Order  
Man. Inst. Operation Header (Add/Update/Delete) -> Asprova Operation
2. Standard Start Time, Standard End Time, Standard Start/End Time
3. Version change
4. Operation location change

# Asprova Link For SAP R/3 (Collaboration)

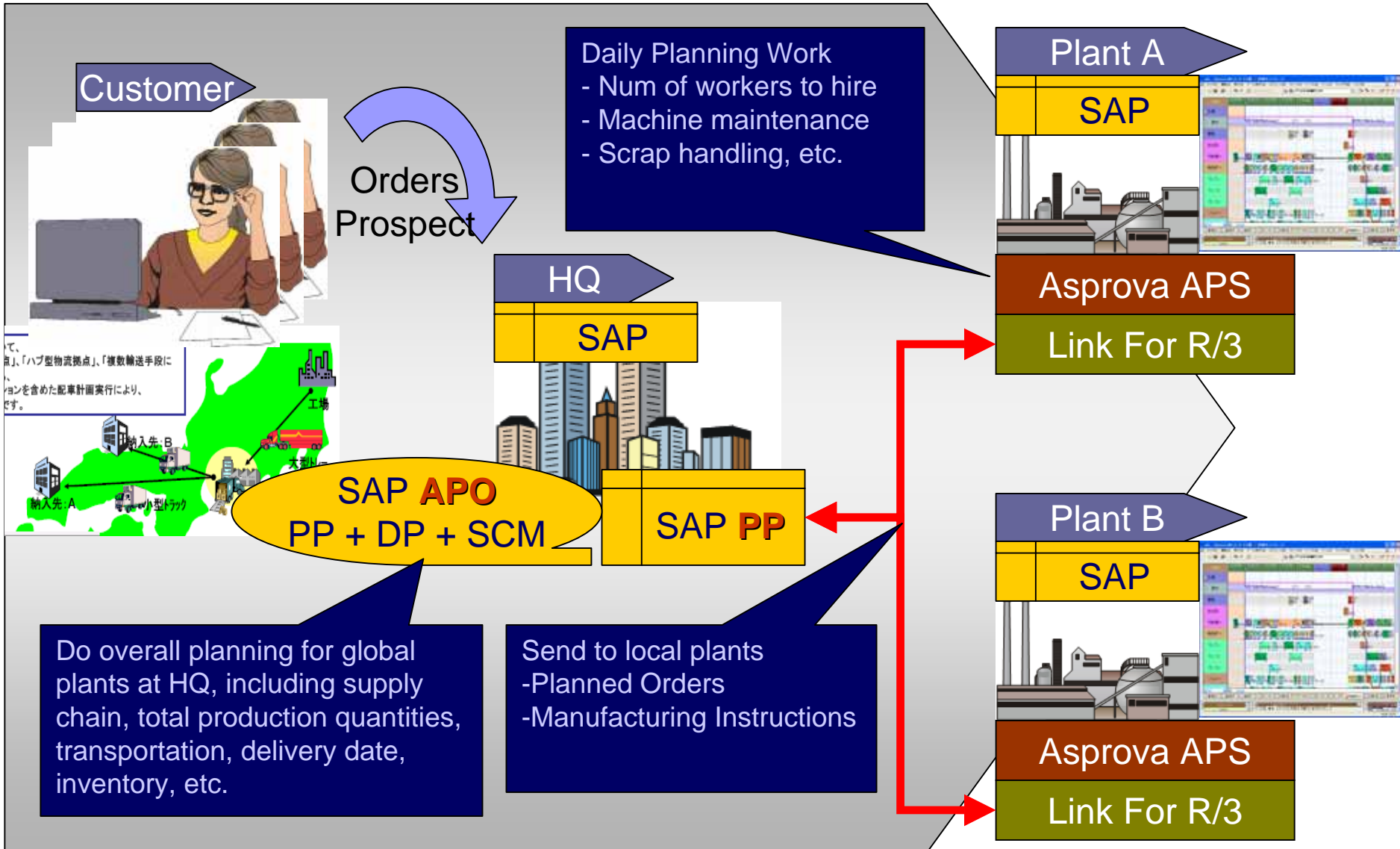

# Asprova Link For SAP R/3 (Structure)

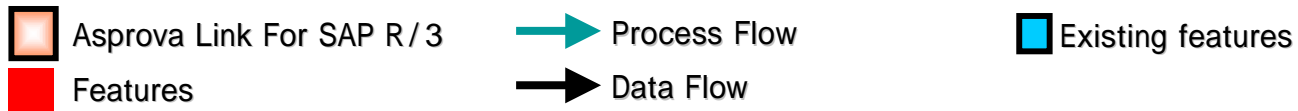
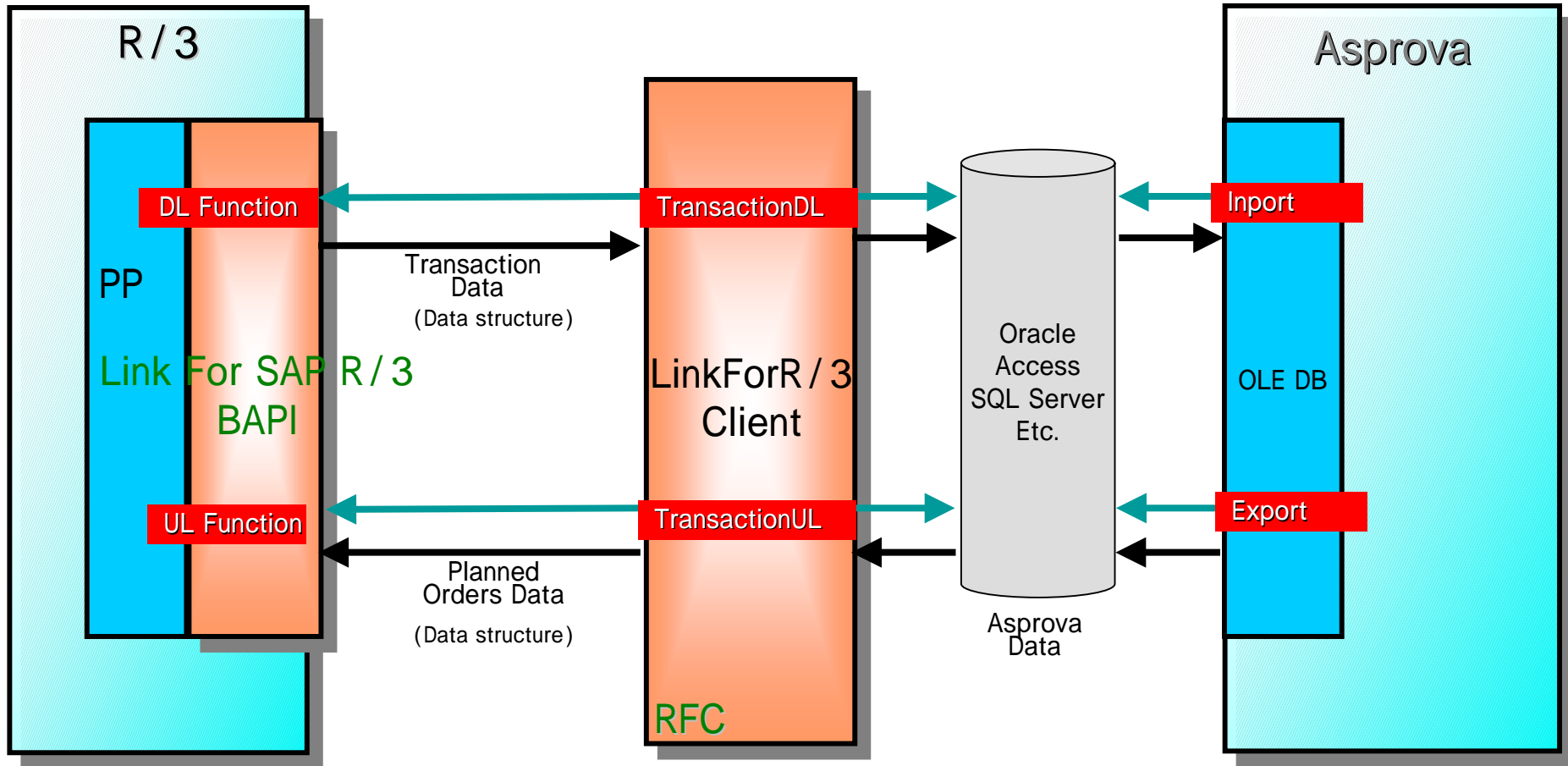

# Asprova Link For SAP R/3 (Structure)

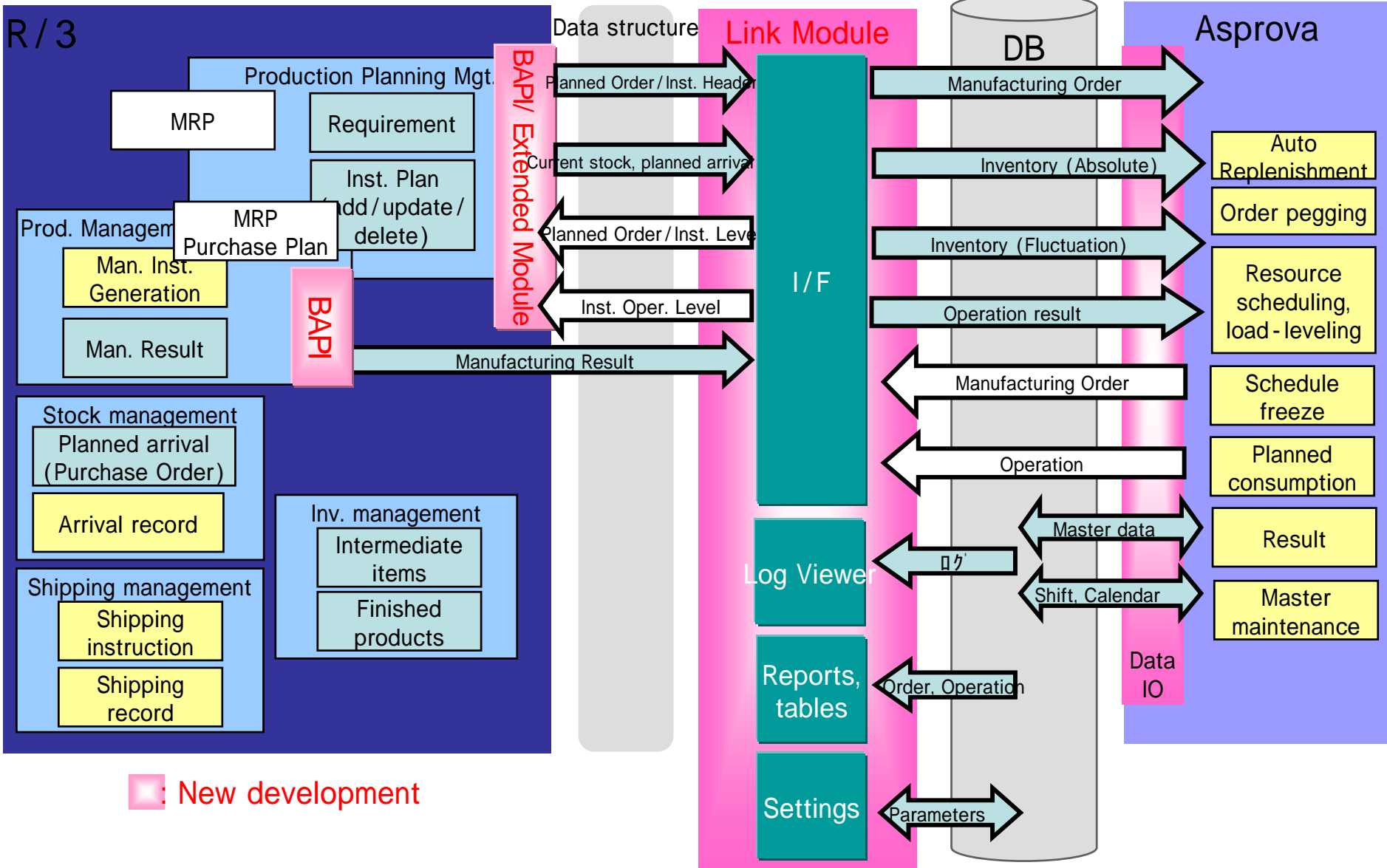

# Asprova Link For SAP R/3 (New Version)

	Asprova Link For R/3 (New Version)
Supported Asprova version	Asprova APS Ver.4 and above
Supported SAP R/3 version	Enterprise, ERP2005
SAP R/3 Linkage subject	PP (Production Planning) module
SAP Certification	Scheduled
SAP R/3 Linkage form	BAPI (Developed by Canon Solution System) + <b>Asprova Extended Functions</b>
Data exchange (R/3 -> Asprova)	
Planned Order	
Manufacturing Instruction	
Instructed Result	
Current Inventory	
Purchase plan	
Item	Considered (2007)
BOM	Considered (2007)
Process Master	Considered (2007)
Workplace	Considered (2007)
Calendar	Considered (2007)
Data exchange (Asprova -> R/3)	
Planned Order (Add/Update/Del.)	
Manufacturing Inst. (Add/Update/Delete)	
Planned release date	<b>January 2007</b>